



WONEN ■ VERZEKEREN ■ HYPOTHEKEN



DEVENTER
Kostersstraat 24



Omschrijving

Bent u op zoek naar een energiezuinige, onderhoudsvriendelijke gezinswoning op een rustige en centrale locatie? Dan is deze verrassend ruime woning zeker een bezichtiging waard.

Nabij winkelcentrum Keizerslanden staat deze verzorgde woning waar comfort, sfeer en praktisch wonen op een prettige manier samenkomen. De woning verkeert in een nette staat van onderhoud en is door de jaren heen zorgvuldig onderhouden. De rustige woonomgeving zonder doorgaand verkeer zorgt voor een gemoedelijke en kindvriendelijke sfeer.

De zonnige achtertuin is gelegen op het zuidwesten, waardoor u vrijwel de gehele dag van de zon kunt genieten.

Daarnaast beschikt de woning over een vrijstaande stenen berging en een praktische achterom.

De locatie is bijzonder gunstig. In de directe omgeving bevinden zich diverse winkels, basisscholen, kinderopvang, sportvoorzieningen, het Rijsterborgherpark en winkelcentrum Keizerslanden. De historische binnenstad van Deventer en het NS-station zijn binnen circa vijf minuten fietsen bereikbaar. Bovendien zijn de A1 en diverse uitvalswegen binnen ongeveer tien minuten met de auto te bereiken.









































Kenmerken & specificaties



Inhoud woning	355 m ³
Woonoppervlakte	100 m ²
Perceeloppervlakte	115 m ²
Bouwjaar	1962

- ✓ Energielabel A
- ✓ Voorzien van gevel-, dak- en vloerisolatie
- ✓ Grotendeels voorzien van HR+ en HR++ beglazing
- ✓ Volledig voorzien van kunststof kozijnen
- ✓ Verwarming en warm water via een Intergas cv-ketel (2024, eigendom)
- ✓ Voorzien van 7 zonnepanelen (2018, eigendom)
- ✓ Openbaar parkeren
- ✓ Meetrapport aanwezig

Plattegronden



Plattegronden



Plattegronden

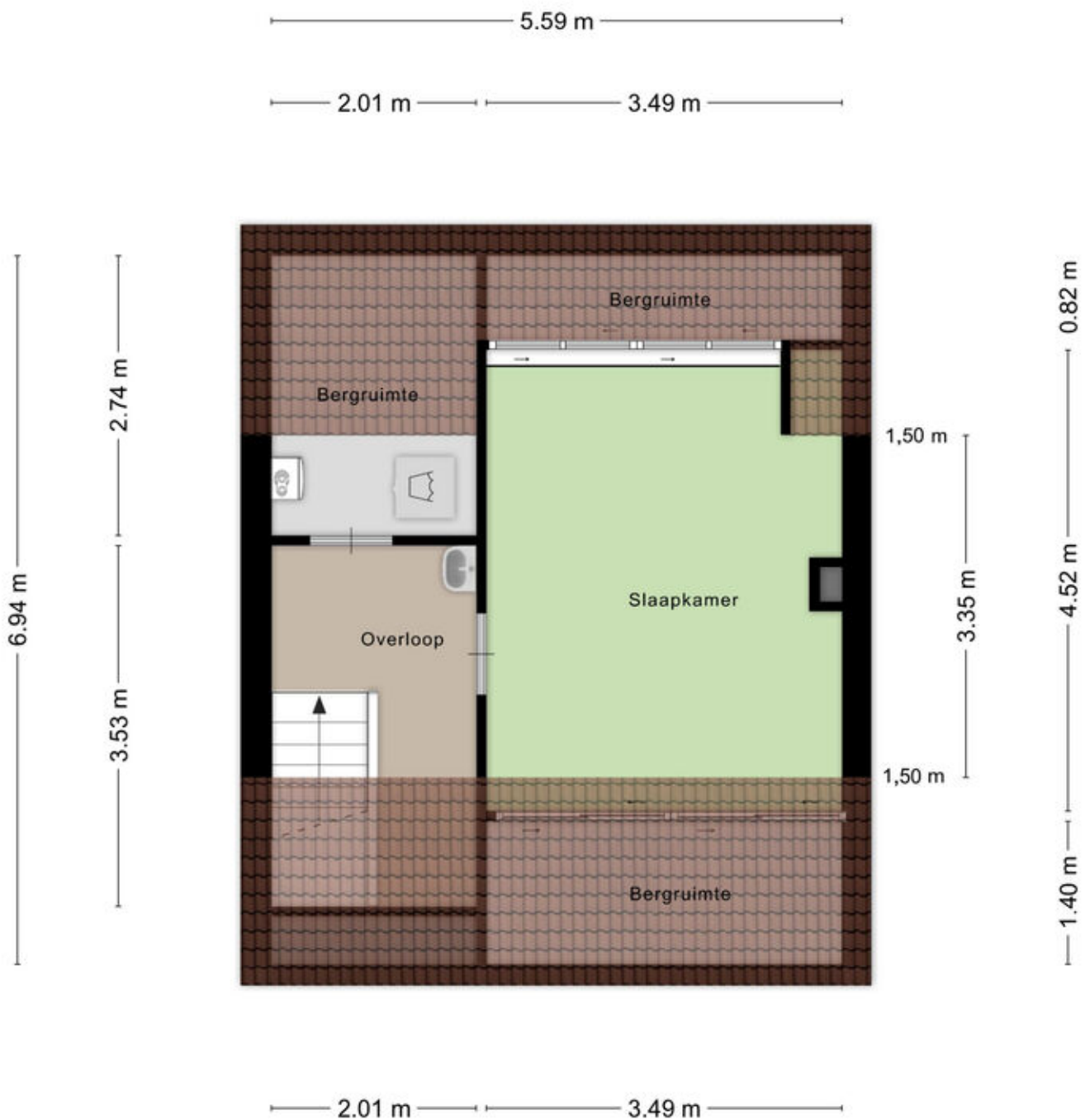

Aan de plattegronden kunnen geen rechten worden ontleend
© Zibber www.zibber.nl

Plattegronden

2.00 m

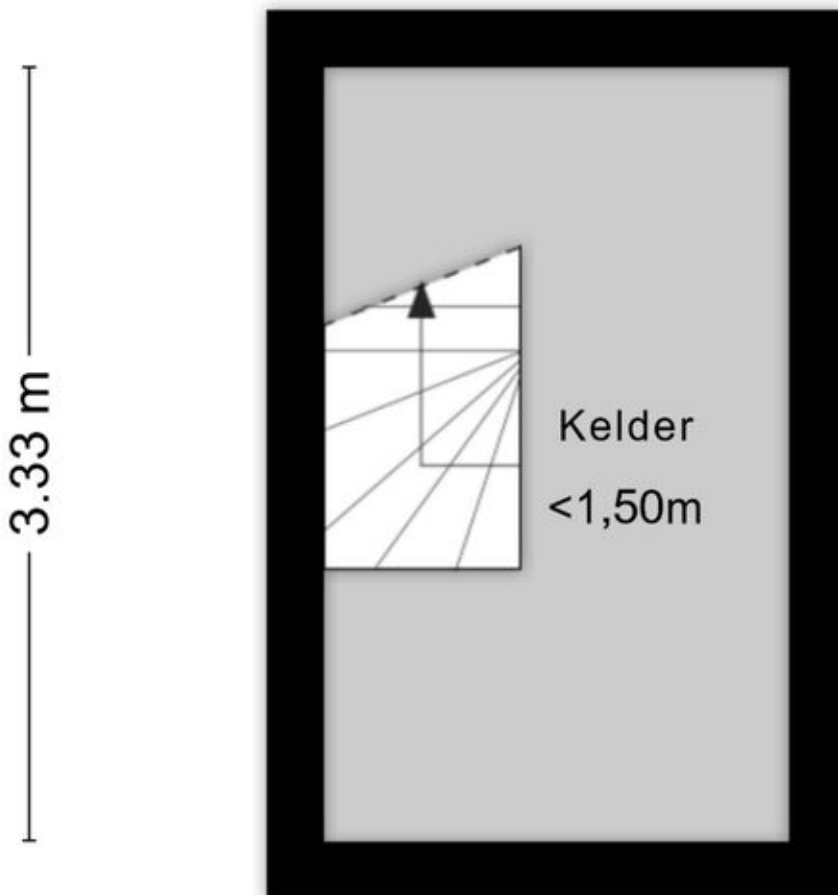

Aan de plattegronden kunnen geen rechten worden ontleend
© Zibber www.zibber.nl

Plattegronden

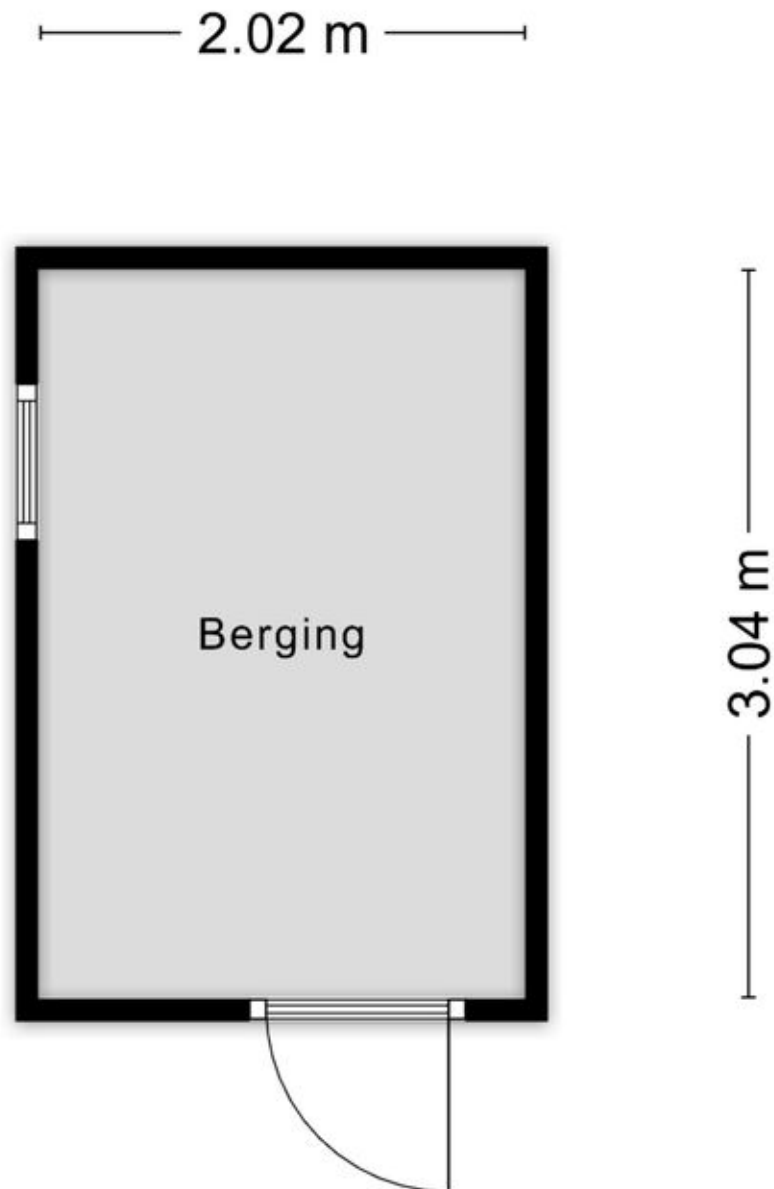

Aan de plattegronden kunnen geen rechten worden ontleend
© Zibber www.zibber.nl

Lijst van zaken

	Blijft achter	Gaat mee	Ter overname
Woning - Interieur			
(Gas)kachels	X		
Designradiator(en)	X		
Verlichting, te weten			
- inbouwspots/dimmers	X		
- opbouwspots/armaturen/lampen/dimmers			X
- losse (hang)lampen		X	
(Losse)kasten, legplanken, te weten			
- Legplanken in kelder	X		
- Lage archiefkast zolder	X		
Raamdecoratie/zonwering binnen, te weten			
- gordijnrails	X		
- gordijnen			X
- rolgordijnen	X		
- lamellen	X		
- (losse) horren/rolhorren	X		
- gordijnen woonkamer voorzijde		X	
Vloerdecoratie, te weten			
- vloerbedekking	X		
- laminaat	X		
- plavuizen	X		
- vloerbedekking trap en overloop	X		
Woning - Keuken			
Keukenblok (met bovenkasten)	X		
Keuken (inbouw)apparatuur, te weten			
- kookplaat	X		
- afzuigkap	X		
- combi-oven/combimagnetron	X		
- koelkast	X		
- vaatwasser	X		
Woning - Sanitair/sauna			
Toilet met de volgende toebehoren			

Lijst van zaken

	Blijft achter	Gaat mee	Ter overname
- toilet	X		
- toiletrolhouder	X		
- toiletborstel(houder)	X		
- fontein	X		
Badkamer met de volgende toebehoren			
- ligbad	X		
- wastafelmeubel	X		
- toiletkast	X		
Woning - Extérieur/installaties/veiligheid/energiebesparing			
(Voordeur)bel	X		
Rookmelders			X
(Klok)thermostaat	X		
Waterslot wasautomaat		X	
Zonnepanelen	X		
Buitenjaloezieën (2)	X		
Warmwatervoorziening, te weten			
- CV-installatie	X		
Tuin - Inrichting			
Tuinaanleg/bestrating	X		
Beplanting	X		
Regenton	X		
Tuin - Verlichting/installaties			
Buitenverlichting	X		
Tuin - Bebouwing			
Tuinhuis/buitenberging	X		
Tuin - Overig			
Overige tuin, te weten			
- vlaggenmast(houder)	X		

Locatie op de kaart

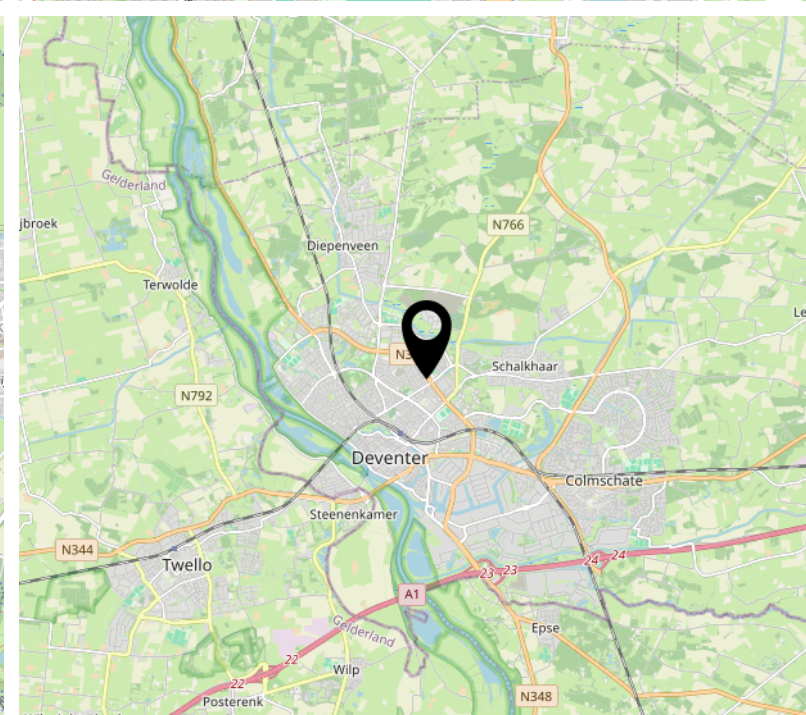
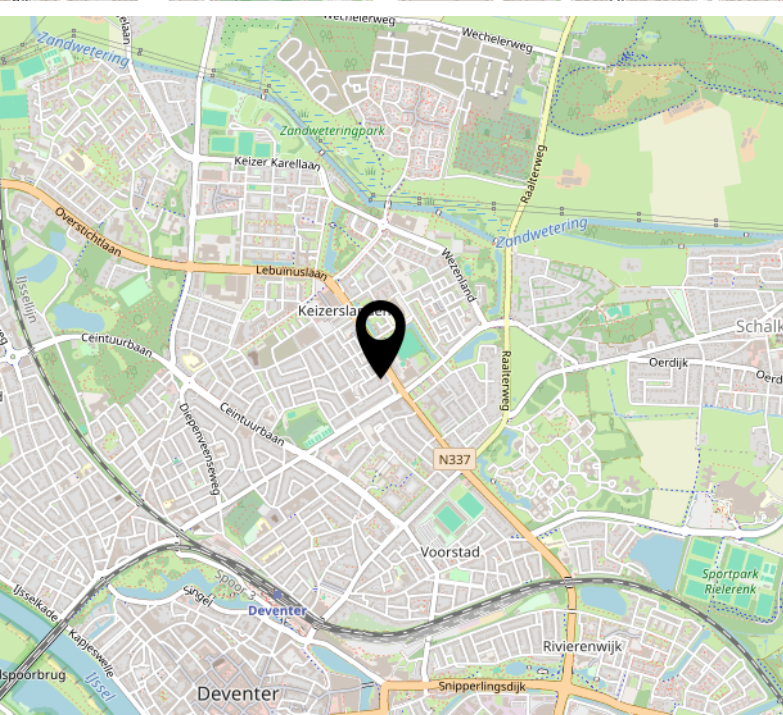
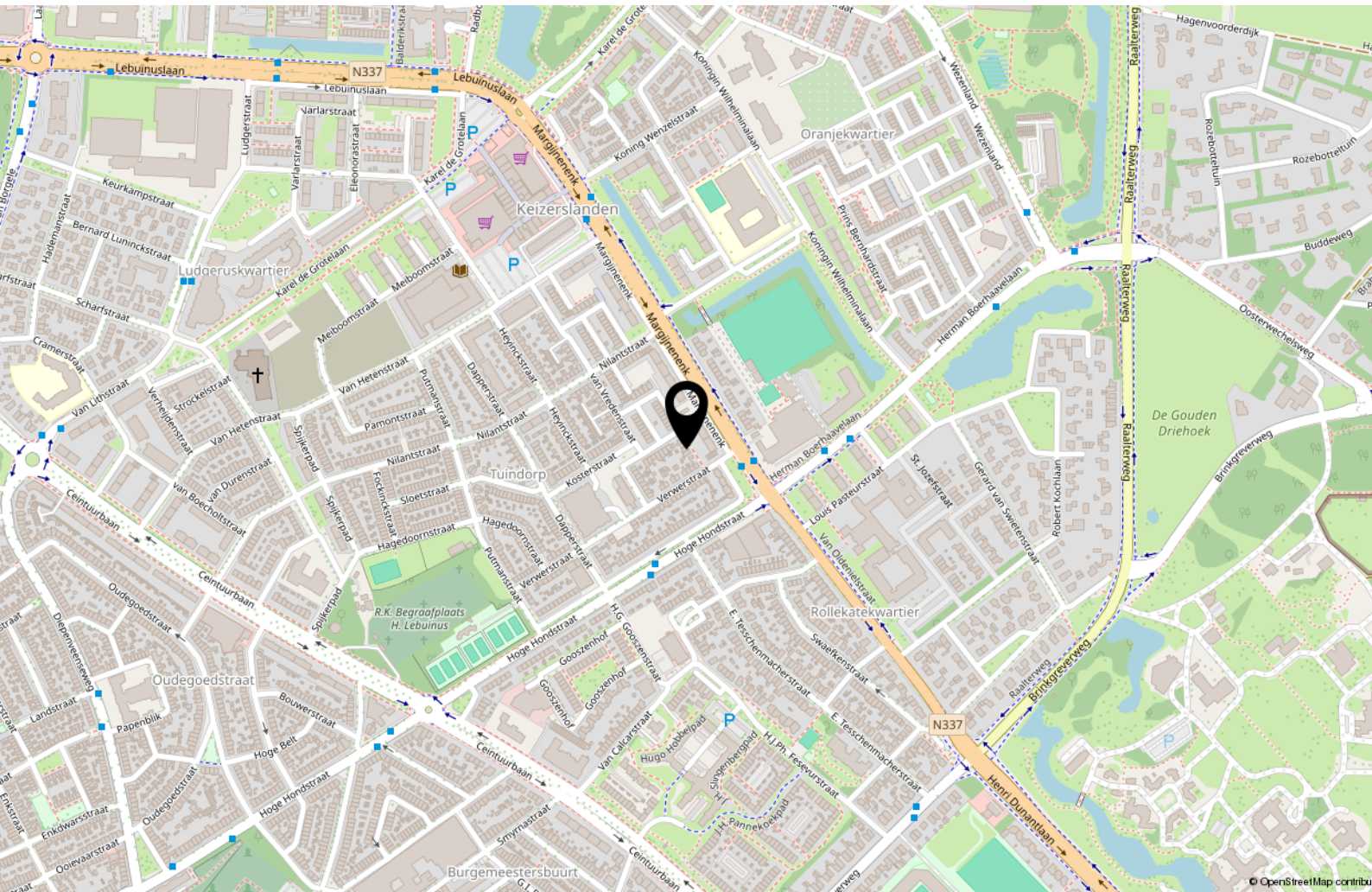

Interesse?



WONEN ■ VERZEKEREN ■ HYPOTHEKEN

Keizerstraat 29
7411 HD Deventer

+31 (0)570 64 22 99
info@adfinismakelaars.nl
www.adfinis.nl