



















Uitzicht op het meer

Referentie 896, woonoppervlakte 57 m², aantal ruimten 4

€ 66.500,=

(Inclusief makelaarscourtage)



 Plaats	Sussac	 Aantal badkamers	1
 Afstand tot dorp	Minder dan 10 minuten	 Aantal toiletten	1
 Ligging	In/nabij dorpje	 Sanitaire voorzieningen	Douche Wastafel Toilet
 Oppervlakte	3.220 m ²	 Nutsaansluitingen	Water Elektra Internet Telefoon
 Type	Bewoonbaar	 Riool	Gemeenteriool
 Bouwperiode	Tussen 1950 en 1980	 Verwarmingstype	Houtkachel(s) Elektrische verwarming
 Renovatie periode	2008	 Aantal bijgebouwen	2
 Woonoppervlakte	57 m ²	 Bijgebouwen	Garage Hangar
 Aantal ruimten	4	 Overige voorzieningen	Kelder
 Slaapkamers	3		

Informatie over milieurisico's voor dit dorp is te vinden op <https://www.georisques.gouv.fr>

Plattegrond

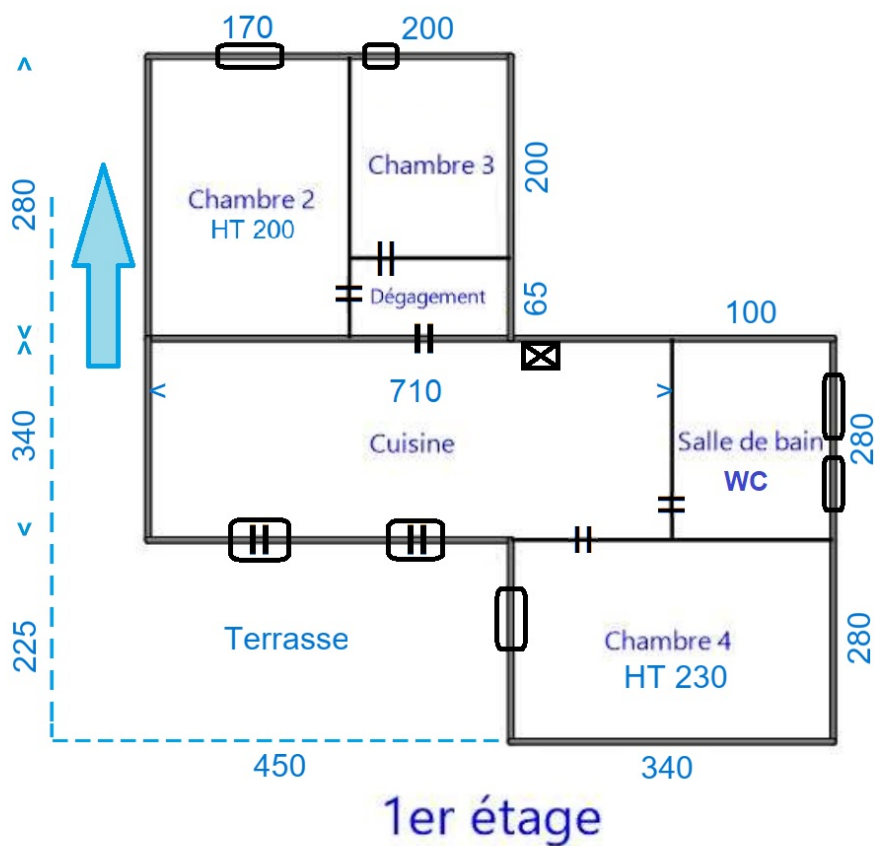
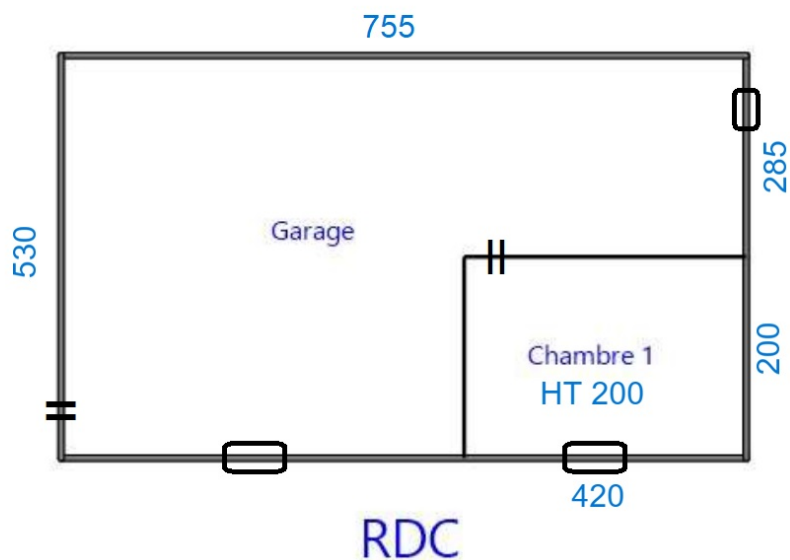



Energie label

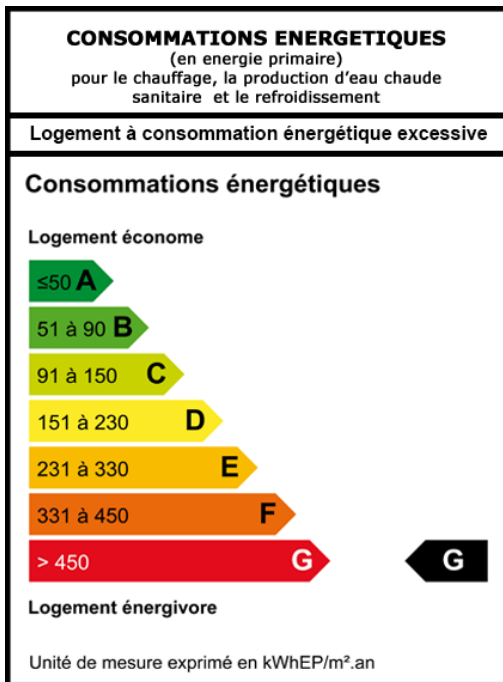

Theoretisch energieverbruik: 881 kWh/m²/jr.

Theoretische energiekosten: tussen € 3.060 en € 4.170 per jaar. Gemiddelde geïndexeerde energieprijzen van 2021 (inclusief abonnementen).

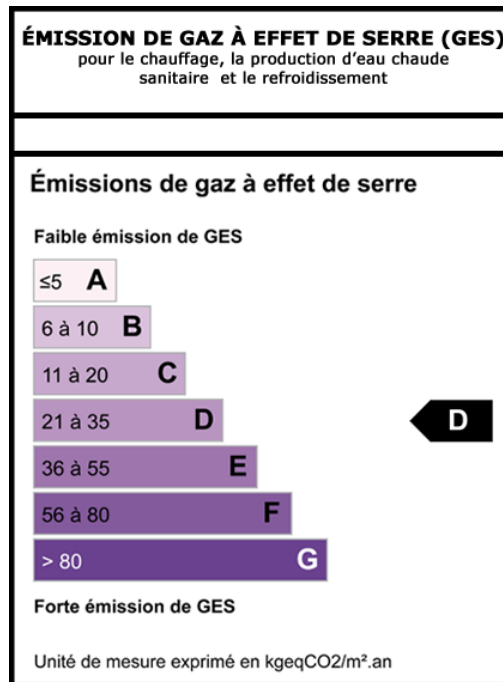

Theoretische CO₂ emissie: 33 kg CO₂/m²/jr.



Een (thuis)bezichtiging plannen?
Dit kan ook via Whatsapp of e-mail

Agence Franco Hollandaise

363 Route des Maquisards

87130 LA CROISILLE SUR BRIANCE

FRANKRIJK

Inschrijving KvK Limoges nr. 521 900 050

Carte Professionnelle nr. 8701 2024 000 000 007

Het kantoor beheert geen gelden

+33 (0)5 55 78 28 84

+33 (0)6 86 22 56 55

info@2ehuisinfrankrijk.com